



Schwienbacher Abbruch Technik

Werkstatt • Lager • Service seit 1977

D-82229 Seefeld (bei München)

Graf-Toerring-Seefeld-Strasse 9b / 17

Tel. 08152 / 998 969-0 Fax.- 9

T.45 DRAINAGE-LÖFFEL *optimal** für Bagger von 6,0 bis 7,5 to

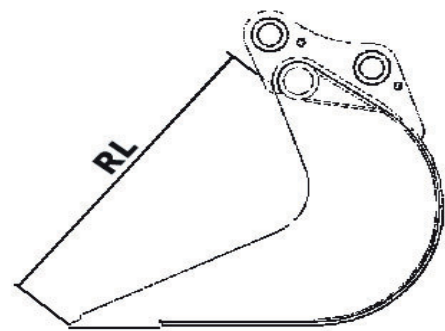
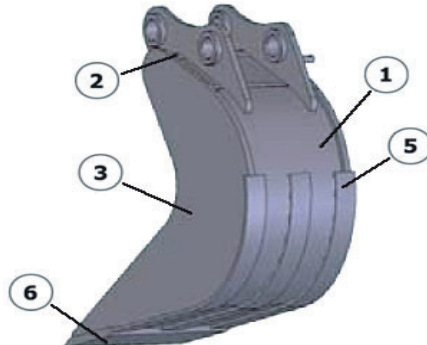
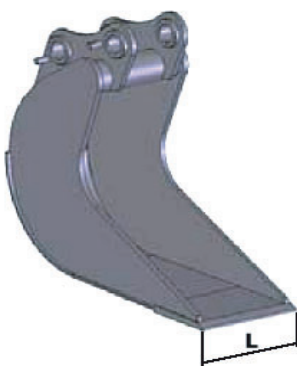
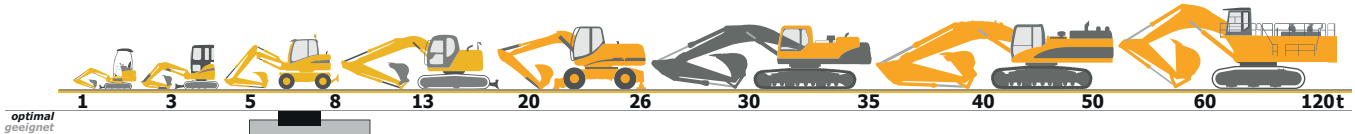

Klasse Class Classe	Bestell Nr. Code Code	Gewicht kg Weight Poids	L mm.			RL mm.		Preis Price List Tarif
T.45 6,0 - 7,5 ton	T45ME0860	~ 116	300 / 400			860		
		1	2	3	4	5	6	
Material	Material Matériel	Fe 510	Fe 510	Fe 510	/	Fe 510	En 250	
Materialstärke	Thickness Espessure	6 mm	121 x 12.5 mm	15 mm	/	50 x 8 mm	200 x 20 mm	

**optimal = für Bagger von 6,0 bis 7,5 t mit Standard-Ausrüstung.*

Benati G 41/G 47/G 49/G 53/2.19; **Benfra** 1.35/1.35B/1.45/6531/8531/BF35 00/E6/E7/E8/E 206; **Case** 580/580E/580F/580G/580K/580SLE/580XLT/590SLE/595SLE/695SM; **Caterpillar** 321/322/428B/428C/43 8C/436C/438D/446B; **Cimas** 930/950/970; **Eurocomach** ES 6500; **Euromach** 6000/6500; **Fai** 100DT/45B/D/E/46C/D/E/575/585/590/595/96DT/890/892/894/898; **Fermec** 860/960; **Fiat Hitachi** FB 7B/FB 90/90.2/FB 100/100.2/FB 110/110.2/FB 200.2/FB 4004WS/FT 700/FR 800; **Ford** 550/555/555C/655C/665/675/675DT/875/NH95; **Foredil** 30.13/40.13; **Halla** 50HE; **Ihi-Imer** 65NX; JCB 3CX/4CX; **Kamo** 3X TURBO/MOBIL 60S; **Kobelco** SK 70SR; **Komatsu** PC 60.7/WB 91R/WB 91R2/WB 9 3R/WB 93R2/WB 95R/WB 97R/WB 97R2/WB 98A; **Kubota** KH 191/KX 191; **Libra** 150S/150W/250/254S; **MF** 50B/D/H/HX/HXB/HXR/HXS/60HX/HXS/750/860/865/960/965; **Macmoter** M 6 M/BW 65; **Mecalac** 8CX/10 MSX; **New Holland** E 70SR/L 90/L 95/L 110/L 115.B; **Palazzani** PB 70.2/PB 80.3/PB 90.3; **Pel Job** EB 706; **Schaeff** HR 31/HR 32/HML 30/HML 31/HML 32/SKB 800/SKB 902; **Takeuchi** TB 070/TB 070W; **Terex** HR 32; **Venieri** VF 9.23/VF 10.23B/VF 10.33/VF 8.23B/C/VF 8.33; **Volvo** BL 71/EC 70/EW 70; **Yanmar** B 70/B 7E/B 7SIGMA/Vio 70.

geeignet = für Bagger von 5,0 bis 10 t je nach Ausrüstung.
Andere **Klassen/Größen** bedingt geeignet. Bei Bedarf bitte anfragen!